



DRYWALL CART MIXED PALLETS

Sur-Pro drywall carts are designed for efficient shipping and storage. Please contact us at 1.888.443.8889 for more details and full pallet pricing.

Mix and match different drywall cart configurations and sizes to qualify for full pallet pricing and prepaid shipping.



Features:

- Load capacity: 3200 LB
- 2 swivel casters and 2 swivel casters with locks
- Non-marking casters or PU casters
- 38" x 10" nylon skid plate for easy loading (residential cart)
- 40" x 12" steel plate (commercial cart)
- High quality powder coated finish

Mixed Pallet Requirements:

Mix of up to 12 carts with even numbers for either model.

Examples: 6 commercial & 6 residential carts
8 commercial & 4 residential carts

MAGNUM TOOL CORP., INC. 1.888.443.8889

WWW.SUR-PRO.COM

Sur-Pro® DRYWALL CARTS



DOR04
Cart with
Non-Marking Casters

DOR04PU
Cart with
Polyurethane Casters

Residential Drywall Cart

LOAD CAPACITY	3200 LB
ITEM WEIGHT	69 LB
PALLET COUNT	12

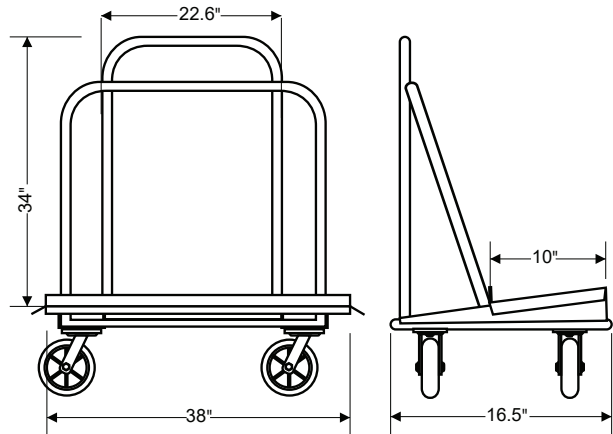

DOA3200
Cart with
Non-Marking Casters

DOA3200PU
Cart with
Polyurethane Casters

Commercial Drywall Cart

LOAD CAPACITY	3200 LB
ITEM WEIGHT	85 LB
PALLET COUNT	12

